

D6-330



Technical Data

Engine designation	D6-330 I
Crankshaft power, kW (hp)	243 (330)
Propeller shaft power, kW (hp)	237 (322)
Engine speed, rpm	3500
Displacement, l (in ³)	5.5 (336)
Number of cylinders	6
Bore/stroke, mm (in.)	103/110 (4.06/4.33)
Compression ratio	17.5:1
Dry weight with HS63AE, kg (lb)	656 (1446)
Dry weight with HS80AE, kg (lb)	677 (1493)
Dry weight with HS80IVE, kg (lb)	721 (1590)
Ratio HS63AE	2.04:1, 1.56:1
Ratio HS63IVE	1.99:1, 1.56:1
Ratio HS80AE	2.5:1, 1.9:1, 1.57:1
Ratio HS80IVE	2.49:1
Emission compliance	IMO NOx, EU RCD, US EPA Tier 3
Rating	R4* & R5**

Technical data according to ISO 8665. With fuel having an LHV of 42700 kJ/kg and density of 840 g/liter at 15°C (60°F).

Merchant fuel may differ from this specification which will influence engine power output and fuel consumption.

*RATING 4. For light planing craft in commercial operation

**RATING 5. For pleasure craft applications, and can be used for high speed planing crafts in commercial applications

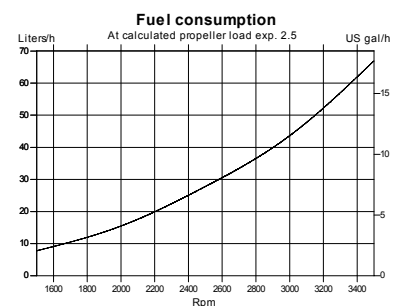
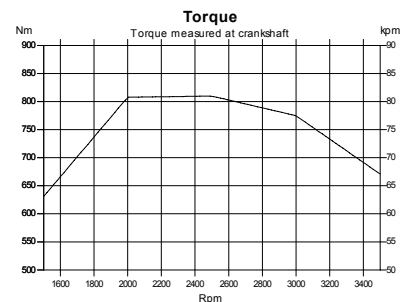
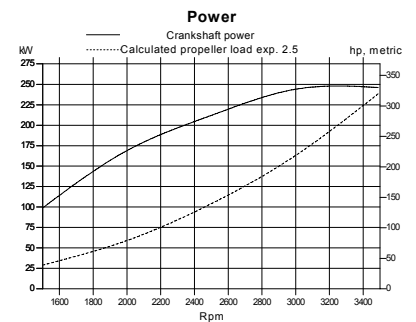

**VOLVO
PENTA**

D6-330

Technical description:

Engine block and head

- Cylinder block and cylinder head made of cast-iron
- Ladder frame fitted to engine block
- 4-valve technology with hydraulic lash adjusters
- Double overhead camshafts
- Oil-cooled pistons with two compression rings and one oil scraper ring
- Integrated cylinder liners
- Replaceable valve seats
- Seven-bearing crankshaft
- Rear-end transmission

Engine mounting

- Flexible engine mounting

Lubrication system

- Easily replaceable separate full-flow and bypass oil filter
- Seawater-cooled tubular oil cooler

Fuel system

- Common rail fuel injection system
- Control unit for processing the injection

- Fine filter with water separator

Air inlet and exhaust system

- Air filter with replaceable insert
- Crankcase gases vented into the air inlet
- Exhaust elbow or exhaust riser
- Freshwater-cooled turbocharger
- Loss of sea water alarm

Cooling system

- Thermostatically regulated freshwater cooling
- Tubular heat exchanger with separate large volume expansion tank
- Coolant system prepared for hot water outlet
- Easily accessible seawater impeller pump

Electrical system

- 12V or 24V two-pole electrical system
- 14V/115A or 28V/80A marine alternator with Zener-diodes to protect the system from peak voltage, and integrated charging regulator with battery sensor cable for maximum use of alternator
- Fuses with automatic reset (12V) and fuses with manual reset (24V)

- Auxiliary stop button

Instruments/control

- Complete instrumentation/display packages, including e-key, the electronic key from Volvo Penta.
- Electronic shift and throttle
- Plug-in connectors

Reverse gear

- Reverse gear with matched drop center and 8° down angle for compact installation and minimum propeller shaft angle. V-drive available.
- Bevel gears which results in smooth running at all speeds
- Hydraulically operated clutch for smooth shifting
- Electrical shifting performed by electromagnetic valves
- When under sail propeller shaft can rotate 24 hours without engine start
- Seawater-cooled oilcooler
- Low speed as option

Option

U.S.C.G./MED (SOLAS) kit available.

Dimensions D6-330/HS80AE

Not for installation

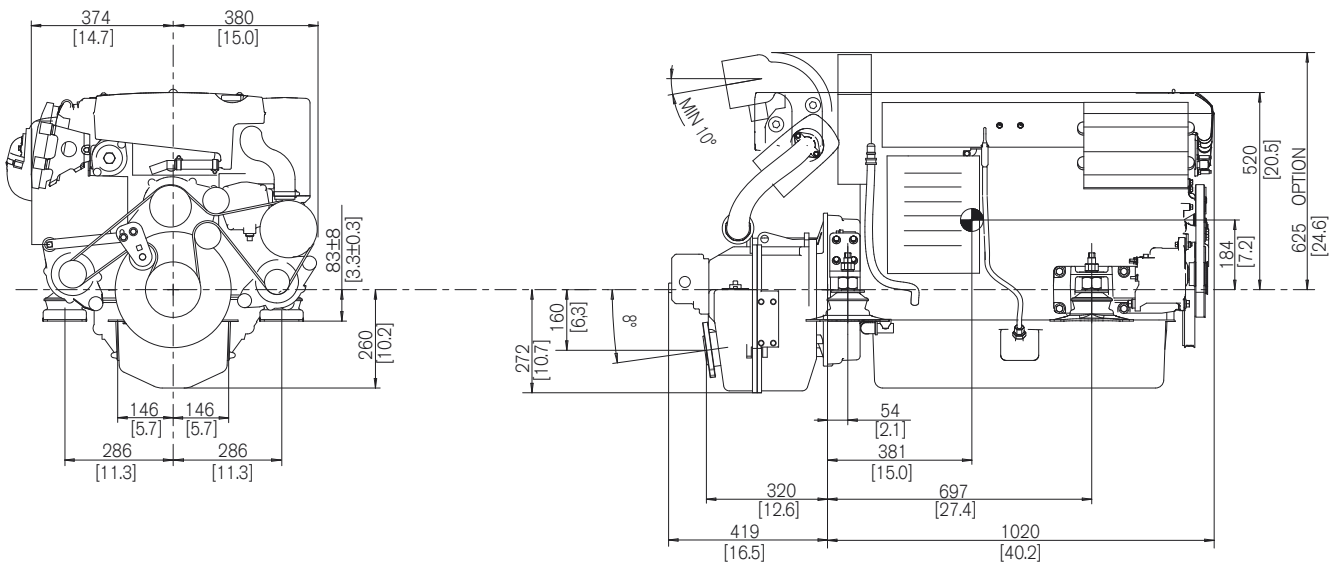

More information

Contact your nearest Volvo Penta dealer for more information about Volvo Penta engines and optional equipment/accessories or go to www.volvopenta.com



Download the Volvo Penta dealer locator App for your iPhone or Android

VOLVO PENTA

AB Volvo Penta

SE-405 08 Göteborg, Sweden
www.volvopenta.com

Not all models, standard equipment and accessories are available in all countries. All specifications are subject to change without notice. The engine illustrated may not be entirely identical to production standard engines.